

# Table of Contents

Welcome to Surprise Valley	1
Homeowners' Association	1
Architectural Department	1
Landscape Contractors	1
Recreation Contractors	1
Covenants, Conditions & Restrictions	1
Homeowner Assessments	2
Parking and Storage	2
Landscape Maintenance	2
Pressurized Irrigation System	3
Renters	3
Speed Limits	4
Common Neighborhood Complaints	4
Covenant Enforcement	4
Farmhouse Clubhouse/Fitness Facility/ Pools/Tennis Courts	5
Important Reminders	6
Summary of Common Design Guidelines	6
Home Additions/Exterior Lighting/ Painting/ Roofing	7
Plantings with Mature Height >10'	7
Plantings with Mature Height <10'	8
Front Yard Planting Beds	8
Planting in Common Areas	8
Detached Storage Buildings	8
Play Structures/Other Play Structures	8
Trampolines	9
Basketball Hoops	9
Swimming Pools and Hot Tubs	9
Water Features	9
Amplification Devices	9
Satellite Dishes/Antennas	9
Decks/Trellises/Gazebos	9
Patio Covers	9
Enclosed Patios/Sunrooms	10
Solar Panels	10
Fence Design and Maintenance	10
Pet Enclosures	12
Mailboxes	12
House Numbers	12
Nuisances	12
Community Contacts	13
Covenant Reminder Notice (Form)	13



## Welcome to Surprise Valley

On behalf of all the members of Surprise Valley, welcome to the neighborhood! We are proud of our community and we look forward to getting to know you. To help you understand and appreciate our special neighborhood, this Homeowners' Handbook has been prepared. It contains important information about Surprise Valley, including the organization and management of our Homeowners' Association, key protective covenants and architectural guidelines, and other items of interest and importance to you as a homeowner and member of Surprise Valley Homeowners' Association (SVHOA). For full covenants and other guidelines go to the SVHOA website at [www.surprisevalleyhoa.com](http://www.surprisevalleyhoa.com).

## Homeowners' Association Management

All property owners within Surprise Valley are members of the Homeowners' Association. Each year, eleven individual neighborhoods meet to elect delegates to a Board of Directors. The Board meets monthly to manage the affairs of the SVHOA. Homeowners are welcome to attend any meeting with advance notification to the Board. Homeowners, whether Board members or not, may also volunteer to serve on one of our committees. These include the Design Committee and Recreation Committee, and other committees that may be established from time to time. All members of the Board and the committees serve as unpaid volunteers. The Neighborhood Manager is a paid position and is responsible for managing all activities including Farmhouse scheduling, general maintenance, assessments, covenant enforcement and all other day to day issues. An outside accounting firm is hired to maintain the SVHOA books and prepare tax returns.

## Architectural Design Committee

The Architectural Design Committee exists to help ensure consistent application of design criteria and requirements included in the CC&Rs and architectural guidelines. All proposed exterior changes to homes and landscaping must be reviewed and approved by the Committee prior to any work commencing. See the Summary of Common Design Guidelines section of this Handbook for more information.

## Landscape Committee

The Landscape Committee works with landscaping contractors focusing on planning, upkeep, and financial management of landscaping in common areas in Surprise Valley.

## Recreation Committee

The purpose of the Recreation Committee is to plan and put on various social events throughout the year. Santa Claus visits the Farmhouse each December during the community tree lighting.

## Covenants, Conditions and Restrictions

All properties and common areas within Surprise Valley are guided by a set of Covenants, Conditions, and Restrictions (CC&Rs). This legal document is provided to each homeowner during financial closing, and each homeowner is legally required to abide by its conditions. These covenants were written for the protection of the

community as a whole, to help maintain its appearance and property values. Links to the governing documents can be found on Surprise Valley website.

## Homeowner Assessments

Under authority of the CC&Rs, the Homeowners Association levies and collects an assessment from each homeowner. The quarterly homeowner assessments cover costs such as maintenance of common areas, pools, tennis courts, signs, utilities, security, neighborhood communications and other operating expenses. The quarterly assessment also includes an assessment for the pressurized irrigation system.

## Parking and Storage

Vehicles used for everyday transportation should be parked in your garage. For safety and visibility of drivers, avoid parking on the street. Avoid parking on sidewalks at any time, even partially. Vehicles parked on sidewalks represent a safety hazard for children and an inconvenience for walkers. Do not park where “no parking” signs are posted as this is a fire lane. Parking on Surprise Way is prohibited.

Boats, campers, travel trailers, motor homes, snowmobiles, motorcycles, watercraft, tent trailers, and other recreational vehicles should be parked in the garage or out of sight behind your fence or at an off-site storage facility. It is permissible to park your RV or boat in your driveway for up to 48 hours for cleaning, loading and unloading.

## Landscape Maintenance

It is the homeowner’s responsibility to keep their property, including trees and landscaping, in good condition. (CC&Rs 4.2 Exterior Maintenance and 4.3 Landscaping) Sidewalks and walkways should kept clear of bushes and tree limbs. We live in a semi-desert environment, and maintaining a healthy green lawn during our hot summers can be a challenge. Here are some tips:

- Crabgrass: apply pre-emergent crabgrass preventer in early spring. Look for the yellow flowers on the forsythia bushes – when they bloom, it’s time to apply the preventer.
- Fertilizer: at least two applications to your lawn, two months apart, with the first application in spring. An alternative to chemical fertilizers is a top-dressing of compost, applied in spring and raked into the grass.
- Weed control: A healthy lawn will resist weeds. Chemical controls may be applied anytime or in combination with fertilizing. If digging weeds by hand, you will need to dig deep to get the entire root, or many weeds will grow back.
- Insect control: Billbugs and grubs are a common and serious problem. They live in the soil and eat the roots of the grass. If you have yellowed areas in your lawn, pull up a bit of grass. If it pulls up easily with few roots attached, you have billbugs or grubs. A chemical control such as Merit is needed to kill the insects. Because of the life cycle of the insects, the timing of application is critical. The first treatment should be made in April/May, with a second treatment in June/July.
- Brown spots in lawn: many possible causes, including a clogged sprinkler head, billbug damage, a lawn fungus, even over-watering. Contact a specialist to be sure of the cause.
- Mowing and trimming: Mow and trim weekly, with the mower blade height set at 2 1/2”.
- As a courtesy, and to avoid violation reminder notices, notify the Neighborhood Manager if you are putting in a new lawn or seeding.

## Pressurized Irrigation System

Each home in Surprise Valley is supplied with landscape irrigation water through a pressurized system that is completely separate from the domestic water system in the community. Your home is levied an irrigation assessment based on the size of your lot, which is included as part of quarterly homeowner assessments.

Every homeowner will have access to the irrigation water every other day for two hours. The irrigation schedule showing time assignments is available on the SVHOA website. It is important you adhere to the watering schedule to maintain optimal water pressure in our neighborhood. This will ensure all homeowners and common areas have sufficient pressure during their set watering period.

Each year the pressurized irrigation is shut down around the end of October. Surprise Valley provides a community-wide sprinkler blowout after shutdown, so you do not need to hire this service.

The Homeowners' Association is responsible for operating and maintaining the irrigation system up to and including the SVHOA Service box that is located on your lot. From that point on, the system is yours to use and maintain. For more information about the irrigation system see the "Pressurized Irrigation System – Rules, Regulations and Information Guide" locate on the SVHOA website.

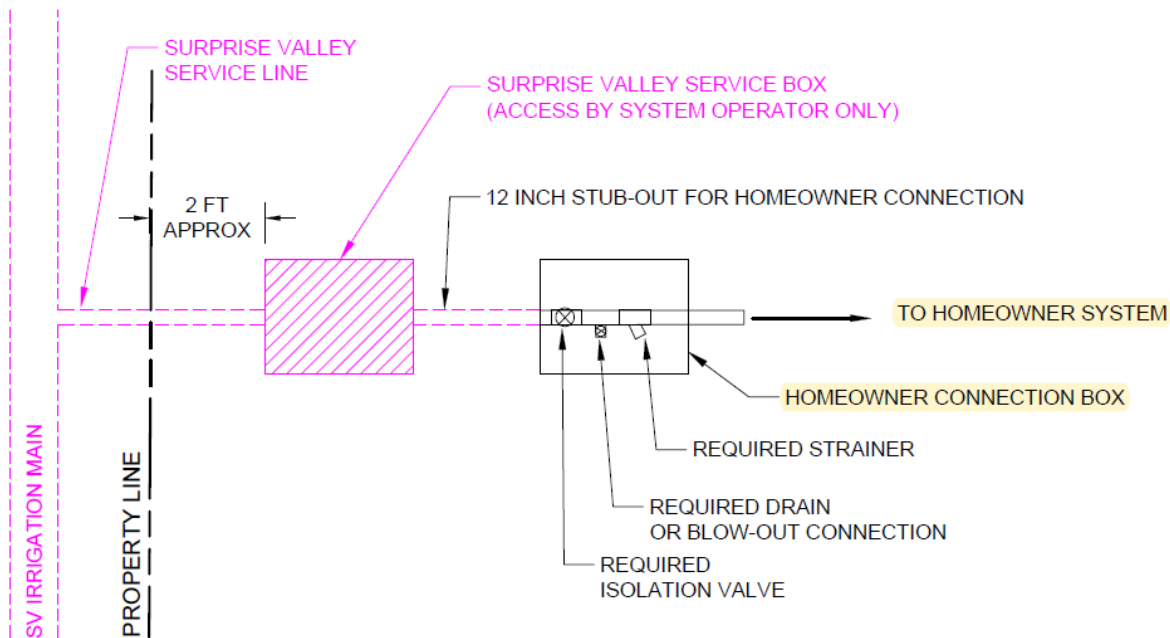

## Renters

If it becomes necessary to rent your home, please ensure your tenants have access to this handbook. Notify the Neighborhood Manager of the names, email addresses, and phone numbers of your tenants so they can be properly welcomed to the neighborhood and receive any vital information. Also, it is helpful if you provide the contact information of the property management company if you are utilizing this service. At times, landscape maintenance suffers at rented homes. Please remember that it is ultimately the homeowner's responsibility to

ensure landscape maintenance stays within neighborhood standards. Many homeowners choose to hire outside companies for landscaping needs when they rent their home, to ensure it's well maintained.

## Speed Limits

**The speed limit in all sections of our individual neighborhoods is 20 mph.** The speed limit on South Surprise Way is 30 mph and the speed limit at signed crosswalks is 15 mph. Violators should be reported promptly to the police noting the vehicle identification and license number. Please discuss this important matter with young adult drivers in your household. In addition, below are two links for communicating speeding and traffic issues with ACHD and Boise City.

Boise City: Neighborhood Contact Officer: <https://www.cityofboise.org/departments/police/specialty-positions/neighborhood-contact-officer/>

ACHD: Traffic Calming (Keeping Your Neighborhood Safe):  
<https://www.achdidaho.org/Departments/Engineering/Traffic/calming.aspx>

## Common Neighborhood Complaints

Most issues and/or concerns can be successfully resolved with neighbor-to-neighbor contact. In turn, it is important to keep an open mind and be willing to listen to the concerns of our neighbors.

The most common complaints by homeowners are:

- ***Pet Etiquette*** - Pets should be on a leash and under control at all times when outside the confines of fenced areas of your yard. Cats should not be allowed to roam free at any time. The pet owner must remove pet litter immediately. Mutt Mitt stations are located along the walking paths for your convenience. Barking and pet nuisances should be reported promptly to Boise City Animal Control at 208-343-3166, not to the Homeowners' Association. (CC&Rs 4.9 Animals/Pets)
- ***Vehicles Speeding*** – Surprise Valley is a family-oriented community with lots of children at play. There are many offenders who exceed the speed limit, putting us all at risk. See the “Speed Limits” section above.
- ***Homeowner Landscape Maintenance*** – It is the responsibility of the homeowner to keep lawns regularly cut and edged; shrubbery and trees trimmed; lawn, planting beds, tree wells, and driveway free of weeds. Bushes and trees should not impede sidewalks or common pathways. (CC&Rs 4.3 Landscaping)
- ***Street Parking*** – A common complaint is regarding the parking of vehicles and recreation vehicles. Please see the “Parking and Storage” section above.
- ***Trash/Recycling/Compost/Glass Bins*** – All collection bins and other unwanted items must be stored **out of public view** until the evening before pickup day and removed from street no later than the evening of pickup day. (CC&Rs 4.4 Nuisances)

## Covenant Enforcement

All members of our neighborhood have acknowledged and, by acceptance of a deed to their homes, have agreed to abide by the Covenants, Conditions and Restrictions (CC&Rs) of Surprise Valley. When a violation of the CC&Rs is observed by the Neighborhood Manager or reported by a neighbor, the following procedure is followed to resolve the issue:

- A “Covenant Reminder Notice” is sent to the homeowner regarding the violation. (See example at end of this handbook.)
- If the violation continues, a second violation notice is sent to the homeowner. The Neighborhood Manager will also attempt to contact the homeowner to resolve the issue and to determine what follow-up action may be necessary. Extenuating circumstances such as a personal emergency, health, and employment will be considered.
- If the violation persists without cooperation, further action will be taken. A \$100 charge will be assessed to the homeowner’s account and use of SVHOA amenities will be suspended.
- Continued violations are turned over to an attorney. A \$200 charge is assessed and any further legal charges may be applied to the homeowner’s account.

## Farmhouse Clubhouse/Fitness Facility/Pool/Tennis Courts

The clubhouse, fitness facility, and other amenities in Surprise Valley are for use by the members of our community and their guests only. Please join in keeping these neighborhood amenities clean, orderly, and safe for all by following rules and guidelines. Since many teenagers use our amenities without parental supervision, it is especially important parents convey all rules to their children. It is never appropriate for anyone to “jump” a pool fence as every homeowner present *must* have their keycard in their possession while using facilities.

Electronic key cards are needed to enter the pool area gates and fitness area and should be with the homeowner at all times. Be sure pool gates are closed and locked after entering and leaving. One electronic key card is issued to each household. Do not lend your key card to other people. Lost key cards can be replaced for \$50 each. Misuse of electronic key cards may lead to loss of HOA amenities.

***Farmhouse Clubhouse*** - The Farmhouse is available for private parties and other events year-round by reservation only. A Rental and Use Agreement must be completed as well as payment of rental fee and cleaning deposit. The host/hostess of the gathering **MUST** be a Surprise Valley resident and **MUST** be present during the entire event. Reserved usage of the Farmhouse facility includes the main floor **ONLY**, with the exception of the HOA management office. Areas excluded from this Agreement include the fitness center, exterior decks, grounds, and pool. Visit the calendar on the SVHOA website to check for availability first before submitting applicable form and payment.

***Fitness Facility*** - The fitness facility is available year-round from 5:00 a.m. to 10:00 p.m. daily.

***Pools*** - Pool season is Memorial Day to Labor Day. Pool hours are 6:00 a.m. to 10:00 p.m. Sunday through Thursday and 6:00 a.m. to 11:00 p.m. on Fridays and Saturdays. Members younger than 13 must be accompanied by a member who is at least 18 years of age to use the pools or fitness facility. Pool rules are posted at each pool but warrant extra attention:

- Swim diapers are required for infants and toddlers. If an accident occurs the pool will be closed for cleanup and the resident at fault may be billed for cost if found negligent.
- No glass containers of any kind. If glass is broken, the resident at fault may be billed for pool cleanup, including refilling water in pool.
- No audio equipment is permitted. Please use headphones.
- No diving, running, roughhousing, or ball playing.
- No inappropriate language.

- Only small floatation devices are permitted.
- No food or drink of any kind is allowed in the pool water.
- No smoking or vaping.
- No bicycles, skateboards, skates, scooters and similar items are allowed. Please park your bikes at racks outside of pool area.
- No animals are allowed within the enclosed fence area of the pool.
- Guest limit is six people. As their host, you must be present at all times with your guests.
- All members are required to cleanup, dispose of trash, and return chairs to their proper area before leaving the pool area. Be considerate and leave the pool area better than you found it.
- **Failure to follow pool rules will be cause for loss of privileges.**

There have been many issues with after-hours use and non-resident use at our pools. A trespass letter is on file with the police, and any homeowner may call the police non-emergency line at 208-377-6790 to report trespassers. Please give the address of the Farmhouse Pool (5240 S Surprise Way) or the Satellite Pool (6075 S Schooner Place).

**Tennis Courts** - Surprise Valley has two tennis courts with painted boundaries for pickleball as well. The courts are for their intended use only. No skates, skateboards, bicycles or scooters of any kind are allowed. Courts cannot be reserved. Please be courteous of others waiting to play and limit your time on courts.

## Important Reminders

- Always complete an Architectural Review and Approval Request Form prior to making any changes to your home exterior or to your yard landscaping, even if the change is minor. You must have approval prior to work commencing.
- Portable basketball hoops should be placed only on the side of driveways and never on sidewalks, streets, or cul-de-sacs, or facing onto these areas. Permanent basketball goals may be installed, but only with approval from the Design Committee.
- Snow removal is the responsibility of each homeowner. Lack of prompt removal of snow from the sidewalk bordering a homeowner's property is a violation of the City of Boise Municipal Code Section 9-08-07.
- Trash/Recycling/Compost collection day is Friday. (Every other week for recycling and every fourth Tuesday for glass.) Place your containers at curbside no earlier than the evening before collection day. Containers must be stored out of view from the street by the end of collection day. On holiday weeks trash collection will be made on Saturday. This schedule applies to the following holidays: New Year's Day, Memorial Day, Independence Day, Labor Day, Thanksgiving, and Christmas.
- The SVHOA schedules one neighborhood-wide garage sale each year. Members are asked take advantage of the neighborhood garage sale and to avoid having individual garage sales, if possible.
- Ensure the Neighborhood Manager has your current email address in order to receive important updates.

## Summary of Common Design Guidelines

Improvements to the exterior of your home and/or landscaping are subject to guidelines of the Surprise Valley Homeowners' Association. These guidelines include the Covenants, Conditions and Restrictions (CC&Rs) and the Design Guidelines. You should have received copies of these legal documents from your title company when you purchased your home. These Summary Guidelines are a supplement to the Design Guidelines. If these Summary Guidelines do not cover your improvement, you must refer instead to the full Design Guidelines. All documents are available on SVHOA website at [www.surprisevalleyhoa.org](http://www.surprisevalleyhoa.org).

Except where noted, you must apply for and receive approval before beginning your improvement. Forms are available online or in a box near the front door of the Farmhouse. Fill out the form and drop it in the mailbox by the front door. City codes may also apply to your improvement and a building permit may be required. Contact the City of Boise for more information.

Important points to keep in mind:

- Don't wait until the last moment to submit your application. Up to 30 days may be required.
- **Improvements constructed without prior approval may be ordered removed at your cost.**
- Don't take the word of a contractor who claims that he will get approval on your behalf. This is never the case. We advise you not to sign a contract or to make a deposit prior to receiving written approval from the committee.
- The goals of the guidelines are to protect, enhance and preserve the value, desirability, and attractiveness of Surprise Valley, and to assure a visually well-integrated, high quality development. Your application will be judged with these goals in mind.
- If a guideline states that approval is not required, you must still follow the guideline. Otherwise, the committee may order that the improvement be removed, at your cost.

**Home Additions** - If you plan to add a room, a story, or any other addition or extension to your home, please refer to the full Design Guidelines. Approval required.

**Exterior Lighting** - If you add lighting to the exterior of your house or in your yard, bulbs must be shielded from the view of your neighbors, either by the fixture itself or by landscaping. Bulbs must be 60 watts or less. Floodlights, spotlights, strobe and flashing lights are prohibited. Approval not required.

**Painting** - All color changes to siding, trim, gutters, and downspouts must be approved in advance. To be approved, color choices must harmonize with neighboring houses and with the surroundings and be of the earth tone color selections. Please provide a paint chip with your application. If you are re-painting your house the exact same color, approval is not required.

**Roofing** - Most houses use 30-year, architectural style composition shingles. Roofing color choices should harmonize with neighboring houses. In Custom Home neighborhoods which were constructed with cedar wood shake roofs, the roof may be replaced with "Presidential Series" composition shingles, or equivalent, that provides look of wood shakes. Approval required.

**Plantings With a Mature Height > 10'** - Approval required.

When choosing a tree (or other large planting) and deciding where to plant it, follow these guidelines:

- Plant at least 6' from any curb.



- Calculate the mature height and spread of the tree. Use this size in all that follows, not the size of the tree when planted.
- For the health of the tree, plant at least one-half the distance of its mature spread away from any building or other tree.
- There are special guidelines in the case of plantings on the north end of your property if there is a neighboring house immediately to your north. In this case, your planting may not block the sun from your neighbor's house. Please ask for assistance if this case applies to you.
- If your back yard borders a common area (other than Surprise Way), or if it has a rim view, plantings should not diminish any neighbor's view of the common area or rim. Plantings within 20' of the rear of your lot (as measured from the rim, the fence, or the rear lot line, as appropriate) could impact a neighbor's view. We suggest you discuss the placement of the plantings with each neighbor affected, and secure their written endorsement of your application. Applications with neighbor endorsements are more likely to be approved by the committee.

***Plantings With a Mature Height < 10'*** - Approval not required.

***Front Yard Planting Beds*** - Use of natural bark or a high-quality "Perma-bark" is recommended. Gravel is not allowed. Raised beds should be edged with stone. Non-raised planting beds or trees may be edged with any landscaping material. Approval not required.

***Planting in Common Areas*** - Please don't plant any tree, shrub, or flowers outside your property. Make suggestions for common area plantings to the Landscape Committee.

***Detached Storage Buildings*** - These are discouraged. Instead, a storage area may be added as an extension to your home, using similar materials for siding, trim, windows, and roof as were used in building your home. Paint colors must match those used on your home. If the configuration of your home does not allow a storage area to be built as an extension to the home, you may apply to build a detached storage building. It must be built using similar materials for siding, trim, windows, and roof as were used in building your home, and must be painted to match your home. Manufactured storage buildings will not meet these guidelines. Refer to city codes for setback requirements. Approval required.

***Play Structures*** - For swing sets, slides, play houses, and similar play structures, follow these guidelines:

- May be installed in the back yard only.
- Only wood construction is allowed. Fabrics, such as awnings, should not be brightly colored (forest green and tan are recommended). Brightly colored or reflective surfaces are discouraged.
- Must be 12' or less in height.
- If the back yard is on the rim front or borders a common area (other than Surprise Way), the play structure may not be placed within the rear setback (typically 20' from the rear fence).
- Any portion that is taller than 6' must be placed at least 10' away from a side or rear property line.
- Wooden structures must be painted or stained to a basic earth tone, or to match the color of the house siding or the fence.
- The structure shall be designed and placed with consideration to your neighbors and to any impact on their views.
- Approval required.

**Other Play Structures** - For skateboard ramps, inflatable structures, mechanized sports training equipment, and any other play or sports structures set up outside your home, follow these guidelines:

- Structures set up for more than 72 hours must be placed in your back yard only.
- Structures must be 12' or less in height, and any portion that is taller than 6' must be placed at least 10' away from a side or rear property line. An exception is allowed for temporary structures set up for less than 72 hours (such as for a child's birthday party.)
- Permanent structures must be of high-quality construction or manufacture.
- The structure shall be placed with consideration to your neighbors and to any impact on their views. The noise generated by the use of the structure shall be a consideration: structures shall be used in such a manner that no prolonged adverse impact on your neighbor's enjoyment of their property shall occur.
- Any structure remaining in place for more than 30 days within a calendar year shall be considered a permanent improvement. You must either remove the structure or make application for approval of a permanent play structure. Approval is not required for structures removed within 30 days of installation.
- This section is not intended to regulate small, easily portable play equipment, such as a 3' plastic slide.

**Trampolines** - A single trampoline may be set up without Committee approval. An in-ground installation is recommended. As with any play structure, place and use the trampoline with consideration for your neighbors.

**Basketball Hoops** - Installation of permanent poles must be approved in advance. Portable hoops may be used without approval. Do not place portable hoops on sidewalks or in streets, (violation of City of Boise Municipal Code as well), and take down if not used for a period of time. Please ensure your basketball hoop meets community standards and is free of damage. (i.e. cracks.) Sandbags should be free of tears as to not to create a nuisance.

**Swimming Pools and Hot Tubs** - May be placed in your back yard only. Be sure to follow all city codes. Approval required.

**Water Features** - Must be 6' or less in height. The water feature must be placed so that the noise of the pump is not audible to any neighbor. Approval required.

**Amplification Devices** - The City of Boise Municipal Code governs the use of amplification devices such as radios, loudspeakers, stereos, wind chimes and other noisemakers. According to city code, sound from such devices may not be plainly audible within any place of residence not the source of the sound (such as your neighbor's home), nor may the sound be plainly audible upon any street at a distance of 100' or more from the source of the sound. This applies at any time of day or night. You may install permanent outdoor speakers without approval; however, your use of these speakers must comply with the city code. Please keep this in mind when renting the clubhouse as well.

**Satellite Dishes/Antennas** - By direction of the Federal Communications Commission, satellite dishes up to 1 meter in diameter and TV antennas up to 12' high may not be prohibited by neighborhood covenants or city ordinances. However, the SVHOA may still regulate placement of the dish. Please place dishes so that they are less visible to your neighbors. Satellite dishes greater than 1 meter in diameter must be screened from public view. Antennas greater than 12' high are not allowed. Approval not required.

**Decks/Trellises/Gazebos** - Must be constructed of a premium wood or a high-quality synthetic such as Trex. Wood construction should be painted or stained a natural wood color, or to match the house siding or trim. Approval required.

***Patio Covers*** - If the cover has a solid roof, then it must be built as an extension of the home, extending from the existing structure, and using similar materials for siding, trim, windows and roof as were used in building your home. Paint colors should match those used on your home. If the cover has a lattice or slat type of roof, it may be built of any high-quality material. Examples of these types of patio covers may be found at the pools. A solid roof that emulates a lattice or slat style, by use of translucent material between the slats, or by a “lattice wrap” is also permitted. Approval required.

***Enclosed Patios/Sunrooms*** - These must be built as an extension of the home, using similar materials for siding, trim, windows, and roof as were used in building your home. Paint colors should match those used on your home. Approval required.

***Solar Panels*** - Approval required.

***Fence Design and Maintenance -***

***General:***

- Fences within Surprise Valley must have design approval from the Design Committee. Because it is the intent of the Design Committee to tie the development together visually, only certain types of high-quality fences will be allowed.
- Fences should be designed to be harmonious within a contiguous group of homes. An example of a contiguous group would be all the houses backing onto a Common Area. Backyard and side-yard fencing within this group should be harmonious as regards type, height, and setbacks.

***Area Definitions:***

- “Common Area” is defined as real property within Surprise Valley boundaries, which the SVHOA maintains for the mutual use and benefit of said local neighborhood association and its members.
- “Natural Area” is defined as an area generally left unmaintained and in its original state. Natural Areas include, but are not limited to property owned by: Boise City, Idaho Power, Eagle Christian Church, BLM (i.e. South Bluff), and Ada County (i.e. Canyon Point) and SVHOA property designated as ‘Natural Areas’ beyond the condos and along the North Rim (i.e. North Rim).
- “Highway 21” is defined as the Highway 21 road right of way.

***Allowed Fence Designs (Two Types):***

- *Split Rail Fence:* A split rail fence approximately three feet high.
- *Solid Cedar Wood Fence:* A solid wood fence of the same type as is found bordering Surprise Way. The allowed height of this type of fence depends upon its location.

***Fence Design Guidelines:***

- No fences are allowed in front yards. (Particular attention to be paid when constructing fences on corner Lots.)
- For backyards of lots not bordering a Common Area and not on a rim-front, either a split rail or a solid wood fence is allowed. A solid wood fence may not exceed 6 feet high.
- For backyards of lots bordering a Common Area, fencing is discouraged. When permitted, only a split rail fence is allowed.
- For backyards of lots bordering a rim-front, only a split rail fence is allowed.

- Any side-yard fence must be built as a “party wall.” (A common wall between two residences, which is also the legal dividing line between the two residences.) The application must be endorsed by both property owners.
- For side-yards of corner lots where the side-yard faces an interior street (other than Surprise Way), fencing is discouraged, but may be approved on a case-by-case basis.
- For side-yards of lots not bordering a Common Area, and not on a rim-front, either a split rail or a solid wood fence is allowed. A solid wood fence may not exceed 6 feet high.
- For side-yards of lots bordering a Common Area or on a rim-front, either a split rail or a solid wood fence is allowed. The height of a solid wood fence must not exceed 6 feet at any point. As the fence approaches the rear lot line, the fence height must step down to no higher than 4 feet. The lower height must continue, at the minimum, for 20 feet from the rear lot line. Setbacks greater than 20 feet may be required to achieve a consistent look with your neighbors, or to maintain a neighbor’s view of the Common Area or rim.
- Fencing installed on the interior of a lot, such as for a privacy screen around a deck, is not permitted. Instead, build an architectural extension of your home, using similar materials for siding and trim, and matching colors. Exceptions are permitted for the purpose of screening utility meter panels and heating/air conditioning units.
- Pet Enclosures: Dog runs and enclosures should be lower than the height of the nearest fence. Homeowners with split rail fences are encouraged to install an “invisible fence” system. With approval, wire mesh may be added to the split rail, but it must be of high quality, with a large mesh size, installed on the house side of the fence, and may not extend higher than the fence posts.

***Fence Maintenance:***

- Split rail fences along Surprise Way, from Amity Road to the west Surprise Valley Subdivision entrance are maintained by the SVHOA.
- Solid wood fences along Surprise Way reflect on the overall appearance of the neighborhood and shall be maintained in its best possible condition for the benefit of the community. Responsibility for maintenance of these solid wood fences is as follows:
  - a. All solid wood fences bordering Surprise Way shall be maintained in good appearance and condition at the expense of the homeowner of the lot on which they are located.
  - b. In addition to fence maintenance described above, the homeowner should prevent soil buildup and sprinkler overspray that may cause the fence slats or header/baseboards to decay, and shall clear trees and shrubs that grow into or over the fence.
  - c. SVHOA will replace external “posts” for solid wood cedar fences, as needed under normal conditions due to weather and or age. Please contact the Neighborhood Manager for these repairs.

Exception: Post or slat repairs/replacement due to damage caused by the homeowner, the homeowner’s pets or their contractors, or the homeowner failing to properly maintain their side of the community fence, shall be the responsibility of the homeowner. If after being given reasonable notice by the SVHOA, fence repairs are not made, the SVHOA may contract the work and all associated costs will be assigned to the respective owner of the property.

***Fence Maintenance - Fences Bordering Common Areas, Natural Areas and Highway 21***

- All split rail and solid wood fences bordering boarding Common Areas, Natural Areas and Highway 21 shall be maintained in good appearance/condition at the expense of the homeowner of the lot on which they are located.
- Exception: Homeowners who believe their split rail fence boarding a Common Area was damaged by the SVHOA landscape contractor should contact the Neighborhood Manager. If the Neighborhood Manager determines the split rail fence was damaged by the landscape contractor then a reasonable number of replacement split rail posts will be provided at no charge to the homeowner to install. The Neighborhood Manager can supply names of fencing contractors, if needed. If after being given reasonable notice by the SVHOA and the split rail posts or solid fence repairs are not made, the SVHOA may contract the work and all associated costs will be assigned to the respective owner of the property.

***Fence Stains:***

- Homeowner maintained fences may be treated with a clear sealer or a stain every few years. Any clear sealer or transparent (unpigmented) stain is permitted without prior approval.
- If homeowner wishes to apply a solid stain consistent to what is applied to the cedar fencing bordering Surprise Way, the SVHOA would encourage you to use **Behr Woodbridge SC-116** color available at Home Depot.
- Stains should be reapplied every five years. Approval is required for any other pigmented stain other than the above mentioned. House Paint is not allowed.
- SVHOA will periodically pressure wash and stain the Surprise Way side of solid wood fence.

***Gates:***

- High quality gates are allowed for backyard split rail fences boarding Common Areas. Wrought iron gates three feet in height are preferred and will be the responsibility of the respective homeowner to install and maintain.
- No gates were included in original solid wood fencing by the developer for fences bordering Surprise Way and the installation of such backyard gates is not allowed. Where “homeowner installed gates” exist, the respective homeowner is responsible for any maintenance or repair of these gates and support posts or slats. If after being given reasonable notice by the SVHOA, the gate repairs are not made, the SVHOA may contract the work and all associated costs will be assigned to the respective owner of the property.

***Pet Enclosures*** - Dog runs and enclosures should be lower than the height of the nearest fence. If you have a split rail fence, you are encouraged to install an “invisible fence” system. If you wish to add a wire mesh to the split rail, it must be of high quality, with a large mesh size, installed on the house side of the fence, and may not extend higher than the fence posts. Approval required.

***Mailboxes*** - Mailboxes and posts must match the original mailbox and post initially provided by the developer. Please ensure your mailbox and post are free from rust or damage. Paint is available for your use from the Farmhouse or if you prefer you may purchase your own paint (use Glidden Premium Exterior Satin Base 3 in Dark Hunter Green). If your mailbox is damaged, the SVHOA will replace your mailbox post and mailbox at no cost to you. Green vinyl 1” numbers are also available at the Farmhouse free of charge. Mailboxes are to be white, Postmaster General Rural Mailbox Standard Size.

**House Numbers** - Original house numbers or similar to those are encouraged to create harmony of graphic design throughout Surprise Valley. The Design Committee must specifically approve the use of alternate house numbers.

**Nuisances** - No rubbish or debris of any kind shall be placed or permitted to accumulate anywhere on the property. No odor or noise nuisances are permitted. No unsightly articles shall be permitted to remain on any lot as to be visible from any other portion of the property. You may not store items such as trash, recycling, compost and glass bins, lawn and gardening equipment, recreation equipment, other equipment, rubbish, etc. in a location where the items are visible from a street, sidewalk, or common area.

### Community Contacts

ACHD	208-387-6100
Ada County Assessor	208-287-7200
Animal Control	208-343-3166
Boise City Planning & Development	208-384-3830
Boise City Utilities	208-384-3735
Boise Police Non-Emergency	208-377-6790
Idaho Firewise, Inc.	<a href="http://www.idahofirewise.org">www.idahofirewise.org</a>
Idaho Power (Outages)	208-388-2323
Intermountain Gas	208-377-6840
Republic Services	208-345-1265
Storm Water Pollution Hotline	208-395-8888
Suez Water	208-362-7304
All Emergencies	911
Next Door	<a href="http://www.nextdoor.com">www.nextdoor.com</a>



## Covenant Reminder Notice

Homeowner: \_\_\_\_\_ Date: \_\_\_\_\_

Address: \_\_\_\_\_

In an effort to maintain the overall appearance of the neighborhood, this is a friendly reminder about covenant violations that require your attention. All homes in SVHOA are subject to the protective covenants which establish certain rules and regulations concerning the external appearance of your home and property. These covenants were written for the protection of the community as a whole which helps maintain your property's value. Your neighbors are depending on you to do your part in keeping this community attractive.

- Landscaping: Lawns regularly cut and edged; shrubbery and trees trimmed; weeds removed from lawn, planting beds, tree wells, and driveway. Bushes and trees should not impede sidewalks or common pathways. (CC&R 4.3)
- Trash Collection: Garbage/Recycling/Compost bins and other unwanted items must be stored out of public view until the evening before pickup day and removed from street no later than the evening of pickup day. (CC&R 4.4)
- Storage: Lawnmowers, wheelbarrows, construction equipment and supplies, recreational equipment, firewood, or any other items not in regular use must be stored out of public view. (CC&R 4.4)
- Basketball Hoops: Portable hoops are allowed, but may not be placed on the sidewalk or in the street per HOA and city code. Please store on driveway or other area of your property. Also, please ensure your basketball hoop meets community standards and is free of damage. (Design Guideline 5.7)
- Boats, RVs, utility trailers, ATVs, snowmobiles, etc., may be parked in your driveway for no longer than 48 hours at a time, for cleaning, loading and unloading only. (CC&R 4.8)
- Signs: No signs are permitted except for a single "For Sale" sign in your front yard. No signs are permitted in common areas. (CC&R 4.17)
- Mailboxes: Mailboxes and posts must match the original mailbox provided by the developer. Please ensure your mailbox and post are free from rust or damage. Vinyl letters and post paint are available at the Farmhouse at no charge. If your mailbox post needs to be replaced please contact the Neighborhood Manager (Design Guideline 5.5)
- House Numbers: The Design Committee must specifically approve alternate physical house numbers. Please ensure house numbers are easily visible and readable from the street. (Design Guideline 5.10)

\_\_\_\_\_

---

—

---

—

Please address this matter by \_\_\_\_\_. Thank you for your cooperation.

If you have any questions regarding this notice, please contact the Neighborhood Manager at 208-368-0058 or [manager@surprisevalleyhoa.com](mailto:manager@surprisevalleyhoa.com). You may also visit the Surprise Valley website at [www.surprisevalleyhoa.com](http://www.surprisevalleyhoa.com) for links to SVHOA CC&R's, Design Guidelines and Homeowners Handbook.