

SURPRISE VALLEY

November 2022

Table of Contents

Welcome to Surprise Valley.....	3
Homeowners' Association Management.....	3
Architectural Design Committee.....	3
Landscape Committee.....	3
Recreation Committee.....	3
Covenants, Conditions and Restrictions.....	4
Homeowner Assessments.....	4
Parking and Storage.....	4
Landscape Maintenance.....	4
Pressurized Irrigation System.....	5
Renters.....	5
Speed Limits.....	6
Common Neighborhood Complaints.....	6
Covenant Enforcement.....	7
Farmhouse Clubhouse/Fitness Facility/Pools/Tennis Courts.....	7
Important Reminders.....	8
Summary of Common Design Guidelines.....	9
Fence Design and Maintenance.....	12
Community Contacts.....	15

Welcome to Surprise Valley

On behalf of all the members of Surprise Valley, welcome to the neighborhood! We are proud of our community and we look forward to getting to know you. To help you understand and appreciate our special neighborhood, this Homeowners' Handbook has been prepared. It contains important information about Surprise Valley, including the organization and management of our Homeowners' Association, key protective covenants and architectural guidelines, and other items of interest and importance to you as a homeowner and member of Surprise Valley Homeowners' Association (SVHOA). For full covenants and other guidelines go to the SVHOA website at www.surprisevalleyhoa.com.

Homeowners' Association Management

All property owners within Surprise Valley are members of the Homeowners' Association. Each year, eleven individual neighborhoods meet to elect delegates to a Board of Directors. The Board meets monthly to manage the affairs of the SVHOA. Homeowners are welcome to attend any meeting with advance notification to the Board. Homeowners, whether Board members or not, may also volunteer to serve on one of our committees. These include the Design Committee and Recreation Committee, and other committees that may be established from time to time. All members of the Board and the committees serve as unpaid volunteers.

SVHOA is a self-managed association, which means there is no management company. SVHOA employs a 1) manager 2) assistant manager 3) pool attendants and 4) landscape manager to conduct day-to-day business activities. This change to a self-managed HOA was made in January 2018 to be more responsive to homeowners and to provide cost savings over hiring a management company. The Neighborhood Manager is a paid position and is responsible for managing all activities including clubhouse scheduling, general maintenance, assessments, covenant enforcement and all other day to day issues. An outside accounting firm is hired to maintain the SVHOA books and prepare tax returns.

Architectural Design Committee

The Architectural Design Committee exists to help ensure consistent application of design criteria and requirements included in the CC&Rs and architectural guidelines. All proposed exterior changes to homes and landscaping must be reviewed and approved by the Committee prior to any work commencing. See the Summary of Common Design Guidelines section of this Handbook for more information.

Landscape Committee

The Landscape Committee works with landscaping contractors focusing on planning, upkeep, and financial management of landscaping in common areas in Surprise Valley. SVHOA's Landscape Manager serves as the chairman of this committee which is responsible for coordinating work with the landscape contractors.

Recreation Committee

The purpose of the Recreation Committee (also called Social Committee) is to plan and put on various social events throughout the year. Santa Claus visits the Farmhouse each December during the community tree lighting.

Covenants, Conditions and Restrictions

All properties and common areas within Surprise Valley are guided by a set of Covenants, Conditions, and Restrictions (CC&Rs). This legal document which each homeowner is legally required to abide by its conditions. These covenants were written for the protection of the community as a whole, to help maintain its appearance and property values. Links to the governing documents can be found on Surprise Valley website.

Homeowner Assessments

Under authority of the CC&Rs, the Homeowners Association levies and collects an assessment from each homeowner. The quarterly homeowner assessments cover costs such as maintenance of common areas, pools, tennis courts, signs, utilities, security, neighborhood communications and other operating expenses. The quarterly assessment also includes an assessment for the pressurized irrigation system and is based on the size of the each lot.

Parking and Storage

Vehicles used for everyday transportation should be parked in your garage. For safety and visibility of drivers, avoid parking on the street. Avoid parking on sidewalks at any time, even partially. Vehicles parked on sidewalks represent a safety hazard for children and an inconvenience for walkers. Do not park where “no parking” signs are posted as this is a fire lane. Parking on Surprise Way is prohibited.

Boats, campers, travel trailers, motor homes, snowmobiles, motorcycles, watercraft, tent trailers, and other recreational vehicles should be parked in the garage or out of sight behind your fence or at an off-site storage facility. It is permissible to park your RV or boat in your driveway for up to 48 hours for cleaning, loading and unloading.

Landscape Maintenance

It is the homeowner’s responsibility to keep their property, including trees and landscaping, in good condition (CC&Rs 4.2 Exterior Maintenance and 4.3 Landscaping). Sidewalks and walkways should kept clear of bushes and tree limbs. We live in a semi-desert environment, and maintaining a healthy green lawn during our hot summers can be a challenge. Here are some tips:

- Crabgrass: apply pre-emergent crabgrass preventer in early spring. Look for the yellow flowers on the forsythia bushes – when they bloom, it’s time to apply the preventer.
- Fertilizer: at least two applications to your lawn, two months apart, with the first application in spring. An alternative to chemical fertilizers is a top-dressing of compost, applied in spring and raked into the grass.
- Weed control: A healthy lawn will resist weeds. Chemical controls may be applied anytime or in combination with fertilizing. If digging weeds by hand, you will need to dig deep to get the entire root, or many weeds will grow back.
- Insect control: Billbugs and grubs are a common and serious problem. They live in the soil and eat the roots of the grass. If you have yellowed areas in your lawn, pull up a bit of grass. If it pulls up easily with few roots attached, you have billbugs or grubs. A chemical control such as Merit is needed to kill the insects. Because of the life cycle of the insects, the timing of application is critical. The first treatment should be made in April/May, with a second treatment in June/July.
- Brown spots in lawn: many possible causes, including a clogged sprinkler head, billbug damage, a lawn fungus, even over-watering. Contact a specialist to be sure of the cause.
- Mowing and trimming: Mow and trim weekly, with the mower blade height set at 2 1/2”.

- As a courtesy, and to avoid violation reminder notices, notify the Neighborhood Manager if you are putting in a new lawn or seeding.

Pressurized Irrigation System

Each home in Surprise Valley is supplied with landscape irrigation water through a pressurized system that is completely separate from the domestic water system in the community. Your home is levied an irrigation assessment based on the size of your lot, which is included as part of quarterly homeowner assessments.

Every homeowner will have access to the irrigation water every other day for two hours. The irrigation schedule showing time assignments is available on the SVHOA website. It is important you adhere to the watering schedule to maintain optimal water pressure in our neighborhood. This will ensure all homeowners and common areas have sufficient pressure during their set watering period.

Each year the pressurized irrigation is shut down around the end of October. Surprise Valley provides a community-wide sprinkler blowout after shutdown, so you do not need to hire this service.

The Homeowners' Association is responsible for operating and maintaining the irrigation system up to and including the SVHOA Service box that is located on your lot. From that point on, the system is yours to use and maintain. For more information about the irrigation system see the "Pressurized Irrigation System – Rules, Regulations and Information Guide" locate on the SVHOA website.

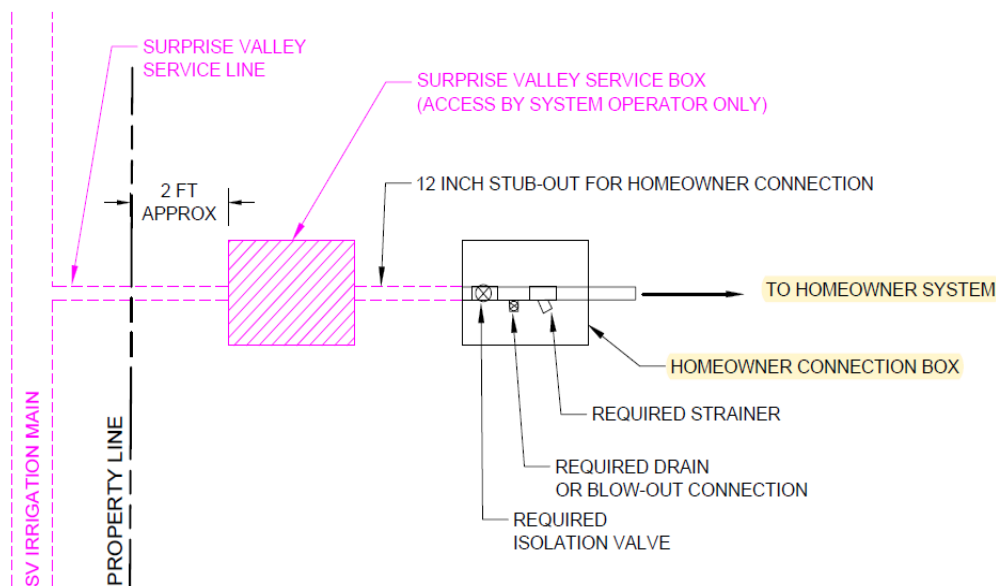

Renters

If it becomes necessary to rent your home, please ensure your tenants have access to this handbook. Notify the Neighborhood Manager of the names, email addresses, and phone numbers of your tenants so they can be properly welcomed to the neighborhood and receive any vital information. Also, it is helpful if you provide the contact information of the property management company if you are utilizing this service. At times, landscape maintenance suffers at rented homes. Please remember that it is ultimately the homeowner's responsibility to ensure landscape maintenance stays within neighborhood standards. Many homeowners choose to hire outside companies for landscaping needs when they rent their home, to ensure it's well maintained.

Speed Limits

The speed limit in all sections of our individual neighborhoods is 20 mph. The speed limit on South Surprise Way is 30 mph and the speed limit at signed crosswalks is 15 mph. Violators should be reported promptly to the police noting the vehicle identification and license number. Please discuss this important matter with young adult drivers in your household. In addition, below are two links for communicating speeding and traffic issues with ACHD and Boise City.

Boise City: Neighborhood Contact Officer:

<https://www.cityofboise.org/departments/police/specialty-positions/neighborhood-contact-officer/>

ACHD: Traffic Calming (Keeping Your Neighborhood Safe):

<https://www.achdidaho.org/Departments/Engineering/Traffic/calming.aspx>

Common Neighborhood Complaints

Most issues and/or concerns can be successfully resolved with neighbor-to-neighbor contact. In turn, it is important to keep an open mind and be willing to listen to the concerns of our neighbors.

The most common complaints by homeowners are:

- ***Pet Etiquette*** - Pets should be on a leash and under control at all times when outside the confines of fenced areas of your yard. Cats should not be allowed to roam free at any time. The pet owner must remove pet litter immediately. Mutt Mitt stations are located along the walking paths for your convenience. Barking and pet nuisances should be reported promptly to Boise City Animal Control at 208-343-3166, not to SVHOA (CC&Rs 4.9 Animals/Pets).
- ***Vehicles Speeding*** – Surprise Valley is a family-oriented community with lots of children at play. There are many offenders who exceed the speed limit, putting us all at risk. See the “Speed Limits” section above.
- ***Homeowner Landscape Maintenance*** – It is the responsibility of the homeowner to keep lawns regularly cut and edged; shrubbery and trees trimmed; lawn, planting beds, tree wells, and driveway free of weeds. Bushes and trees should not impede sidewalks or common pathways (CC&Rs 4.3 Landscaping).
- ***Street Parking*** – A common complaint is regarding the parking of vehicles and recreation vehicles. Please see the “Parking and Storage” section above.
- ***Trash/Recycling/Compost/Glass Bins*** – All collection bins and other unwanted items must be stored **out of public view** until the evening before pickup day and removed from street no later than the evening of pickup day (CC&Rs 4.4 Nuisances).
- ***Signs and Flags*** – Signs and flags in front yards may be offensive to your neighbors. The following signs and flags are permitted.
 - a. Political Signs - candidate and ballot initiative signs are allowed beginning 60 days prior to an election and must be taken down 14 days after the election.
 - b. Flags permitted are those allowed by Idaho American, State of Idaho, MIA/POW, Armed service branch. Sports team game day flags are also allowed.

Covenant Enforcement

All members of our neighborhood have acknowledged and, by acceptance of a deed to their homes, have agreed to abide by the Covenants, Conditions and Restrictions (CC&Rs) of Surprise Valley. When a violation of the CC&Rs is observed by the Neighborhood Manager or reported by a neighbor, the following procedure is followed to resolve the issue:

- A “Covenant Reminder Notice” is sent to the homeowner regarding the violation. (See example at end of this handbook.)
- If the violation continues, a second violation notice is sent to the homeowner. The Neighborhood Manager will also attempt to contact the homeowner to resolve the issue and to determine what follow-up action may be necessary. Extenuating circumstances such as a personal emergency, health, and employment will be considered.
- If the violation persists without cooperation, use of SVHOA amenities will be suspended.
- Continued violations are turned over to an attorney.

Farmhouse Clubhouse/Fitness Facility/Pools/Tennis Courts

The clubhouse, fitness facility, and other amenities in Surprise Valley are for use by the members of our community and their guests only. Please join in keeping these neighborhood amenities clean, orderly, and safe for all by following rules and guidelines. Since many teenagers use our amenities without parental supervision, it is especially important parents convey all rules to their children. It is never appropriate for anyone to “jump” a pool fence as every homeowner present *must* have their keycard in their possession while using facilities.

Electronic key cards are needed to enter the pool area gates and fitness area and should be with the homeowner at all times. Be sure pool gates are closed and locked after entering and leaving. One electronic key card is issued to each household. Do not lend your key card to other people. Lost key cards can be replaced for \$50 each. Misuse of electronic key cards may lead to loss of HOA amenities.

Farmhouse Clubhouse - The Farmhouse is available for private parties and other events year round by reservation only. A Rental and Use Agreement must be completed, as well as payment of the appropriate rental fee and cleaning deposit. The host/hostess of the gathering **MUST** be a Surprise Valley resident and **MUST** be present during the entire event. Reserved usage of the Farmhouse facility includes the main floor **ONLY**, with the exception of the HOA management office. Areas excluded from this Agreement include the fitness center, exterior decks, grounds, and pool. Visit the calendar on the SVHOA website to check for availability first before submitting applicable form and payment.

Fitness Facility - The fitness facility is available year-round from 5:00 a.m. to 10:00 p.m. daily.

Pools - Pool season is Memorial Day to Labor Day. Pool hours are 6:00 a.m. to 10:00 p.m. Sunday through Thursday and 6:00 a.m. to 11:00 p.m. on Fridays and Saturdays. Members younger than 13 must be accompanied by a member who is at least 18 years of age to use the pools or fitness facility. Pool rules are posted at each pool but warrant extra attention:

- Swim diapers are required for infants and toddlers. If an accident occurs the pool will be closed for cleanup and the resident at fault may be billed for the cleanup cost if found negligent.
- No glass containers of any kind. If glass is broken, the resident at fault may be billed for pool cleanup, including refilling water in pool.
- No audio equipment is permitted. Please use headphones.

- No diving, running, roughhousing, or ball playing.
- No inappropriate language.
- Only small floatation devices are permitted.
- No food or drink of any kind is allowed in the pool water.
- No smoking or vaping.
- No bicycles, skateboards, skates, scooters and similar items are allowed. Please park your bikes at racks outside of pool area.
- No animals are allowed within the enclosed fence area of the pool.
- Guest limit is six people. As their host, you must be present at all times with your guests.
- All members are required to cleanup, dispose of trash, and return chairs to their proper area before leaving the pool area. Be considerate and leave the pool area better than you found it.
- **Failure to follow pool rules will be cause for loss of privileges.**

There have been many issues with after-hours use and non-resident use at our pools. A trespass letter is on file with the police, and any homeowner may call the police non-emergency line at 208-377-6790 to report trespassers. Please give the address of the:

Farmhouse Pool:	5240 S Surprise Way
Satellite Pool:	6075 S Schooner Place

Tennis Courts - Surprise Valley has two tennis courts with painted boundaries for pickleball as well. The courts are for their intended use only. No skates, skateboards, bicycles or scooters of any kind are allowed. Courts cannot be reserved. Please be courteous of others waiting to play and limit your time on the court.

Important Reminders

- Always complete an Architectural Review & Approval Request Form prior to making any changes to your home exterior or to your yard landscaping, even if the change is minor. You must have approval prior to work commencing.
- Portable basketball hoops should be placed only on the side of driveways and never on sidewalks, streets, or cul-de-sacs, or facing onto these areas. Permanent basketball goals may be installed, but only with approval from the Design Committee.
- Snow removal is the responsibility of each homeowner. Lack of prompt removal of snow from the sidewalk bordering a homeowner's property is a violation of the City of Boise Municipal Code Section 9-08-07.
- Trash/Recycling/Compost collection day is Friday. (Every other week for recycling and every fourth Tuesday for glass.) Place your containers at curbside no earlier than the evening before collection day. Containers must be stored out of view from the street by the end of collection day. On holiday weeks trash collection will be made on Saturday. This schedule applies to the following holidays: New Year's Day, Memorial Day, Independence Day, Labor Day, Thanksgiving, and Christmas. See Boise City Recycling Calendar: <https://www.cityofboise.org/departments/public-works/curb-it/recycling/>

- The SVHOA schedules one neighborhood-wide garage sale each year. Members are asked take advantage of the neighborhood garage sale and to avoid having individual garage sales, if possible.
- Ensure the Neighborhood Manager has your current email address in order to receive important updates.

Summary of Common Design Guidelines

Improvements to the exterior of your home and/or landscaping are subject to guidelines of the Surprise Valley Homeowners' Association. These guidelines include the Covenants, Conditions and Restrictions (CC&Rs) and the Design Guidelines. You should have received copies of these legal documents from your title company when you purchased your home. These Summary Guidelines are a supplement to the Design Guidelines. If these Summary Guidelines do not cover your improvement, you must refer instead to the full Design Guidelines. All documents are available on SVHOA website at www.surprisevalleyhoa.org.

Except where noted, you must apply for and receive approval before beginning your improvement. Forms are available on the SVHOA website or in a box near the front door of the Farmhouse. Fill out the form and drop it in the mailbox by the front door. City codes may also apply to your improvement and a building permit may be required. Contact the City of Boise for more information.

Important points to keep in mind:

- Don't wait until the last moment to submit your application. Up to 30 days may be required.
- **Improvements constructed without prior approval may be ordered removed at your cost.**
- Don't take the word of a contractor who claims that he will get approval on your behalf. This is never the case. We advise you not to sign a contract or to make a deposit prior to receiving written approval from the committee.
- The goals of the guidelines are to protect, enhance and preserve the value, desirability, and attractiveness of Surprise Valley, and to assure a visually well-integrated, high quality development. Your application will be judged with these goals in mind.
- If a guideline states that approval is not required, you must still follow the guideline. Otherwise, the committee may order that the improvement be removed, at your cost.

Home Additions - If you plan to add a room, a story, or any other addition or extension to your home, please refer to the full Design Guidelines. Approval required.

Exterior Lighting - If you add lighting to the exterior of your house or in your yard, bulbs must be shielded from the view of your neighbors, either by the fixture itself or by landscaping. Bulbs must be 60 watts or less. Floodlights, spotlights, strobe and flashing lights are prohibited. Approval not required.

Painting - All color changes to siding, trim, gutters, and downspouts must be approved in advance. To be approved, color choices must harmonize with neighboring houses and with the surroundings and be of the earth tone color selections. Please provide a paint chip with your application. If you are re-painting your house the exact same color, approval is not required.

Roofing - Most houses use 30-year, architectural style composition shingles. Roofing color choices should harmonize with neighboring houses. In Custom Home neighborhoods which were originally constructed with cedar wood shake roofs, the roof may be replaced with "Presidential Series" composition shingles, or equivalent, that provides look of wood shakes. Approval required.

Plantings With a Mature Height > 10 ft - Approval required.

When choosing a tree (or other large planting) and deciding where to plant it, follow these guidelines:

- Plant at least 6 ft from any curb.
- Calculate the mature height and spread of the tree. Use this size in all that follows, not the size of the tree when planted.
- For the health of the tree, plant at least one-half the distance of its mature spread away from any building or other tree.
- There are special guidelines in the case of plantings on the north end of your property if there is a neighboring house immediately to your north. In this case, your planting may not block the sun from your neighbor's house. Please ask for assistance if this case applies to you.
- If your back yard borders a common area (other than Surprise Way), or if it has a rim view, plantings should not diminish any neighbor's view of the common area or rim. Plantings within 20 ft of the rear of your lot (as measured from the rim, the fence, or the rear lot line, as appropriate) could impact a neighbor's view. We suggest you discuss the placement of the plantings with each neighbor affected, and secure their written endorsement of your application. Applications with neighbor endorsements are more likely to be approved by the committee.

Plantings With a Mature Height < 10 ft - Approval not required.

Front Yard Planting Beds - Use of natural bark or a high-quality "Perma-bark" is recommended. Gravel is not allowed. Raised beds should be edged with stone. Non-raised planting beds or trees may be edged with any landscaping material. Approval not required.

Planting in Common Areas - Please don't plant any tree, shrub, or flowers outside your property. Make suggestions for common area plantings to the Landscape Committee.

Detached Storage Buildings - These are discouraged. Instead, a storage area may be added as an extension to your home, using similar materials for siding, trim, windows, and roof as were used in building your home. Paint colors must match those used on your home. If the configuration of your home does not allow a storage area to be built as an extension to the home, you may apply to build a detached storage building. It must be built using similar materials for siding, trim, windows, and roof as were used in building your home, and must be painted to match your home. Manufactured storage buildings will not meet these guidelines. Refer to city codes for setback requirements. Approval required.

Play Structures - For swing sets, slides, play houses, and similar play structures, follow these guidelines:

- May be installed in the back yard only.
- Only wood construction is allowed. Fabrics, such as awnings, should not be brightly colored (forest green and tan are recommended). Brightly colored or reflective surfaces are discouraged.
- Must be 12 ft or less in height.
- If the backyard is on the rim front or borders a common area (other than Surprise Way), the play structure may not be placed within the rear setback (typically 20 ft from the rear fence).
- Any portion that is taller than 6 ft must be placed at least 10 ft away from a side or rear property line.
- Wooden structures must be painted or stained to a basic earth tone, or to match the color of the house siding or the fence.
- The structure shall be designed and placed with consideration to your neighbors and to any impact on their views.
- Approval required.

Other Play Structures - For skateboard ramps, inflatable structures, mechanized sports training equipment, and any other play or sports structures located outside your home, follow these guidelines:

- Structures to be setup for more than 72 hours must be placed in your backyard only.
- Structures must be 12 ft or less in height, and any portion that is taller than 6 ft must be placed at least 10 ft away from a side or rear property line. An exception is allowed for temporary structures set up for less than 72 hours (such as for a child's birthday party.)
- Permanent structures must be of high-quality construction or manufacture.
- The structure shall be placed with consideration to your neighbors and to any impact on their views. The noise generated by the use of the structure shall be a consideration: structures shall be used in such a manner that no prolonged adverse impact on your neighbor's enjoyment of their property shall occur.
- Any structure remaining in place for more than 30 days within a calendar year shall be considered a permanent improvement. You must either remove the structure or make application for approval of a permanent play structure. Approval is not required for structures removed within 30 days of installation.
- This section is not intended to regulate small, easily portable play equipment, such as a 3 ft plastic slide.

Trampolines - A single trampoline may be set up without Design Committee approval. An in-ground installation is recommended. As with any play structure, place and use the trampoline with consideration for your neighbors.

Basketball Hoops - Installation of permanent poles must be approved in advance. Portable hoops may be used without approval. Do not place portable hoops on sidewalks or in streets, (violation of City of Boise Municipal Code as well), and take down if not used for a period of time. Please ensure your basketball hoop meets community standards and is free of damage. (i.e. cracks.) Sandbags should be free of tears as to not to create a nuisance.

Swimming Pools and Hot Tubs - May be placed in your back yard only. Be sure to follow all city codes. Approval required.

Water Features - Must be 6 ft or less in height. The water feature must be placed so that the noise of the pump is not audible to any neighbor. Approval required.

Amplification Devices - The City of Boise Municipal Code governs the use of amplification devices such as radios, loudspeakers, stereos, wind chimes and other noisemakers. According to city code, sound from such devices may not be plainly audible within any place of residence not the source of the sound (such as your neighbor's home), nor may the sound be plainly audible upon any street at a distance of 100 ft or more from the source of the sound. This applies at any time of day or night. You may install permanent outdoor speakers without approval; however, your use of these speakers must comply with the city code. Please keep this in mind when renting the clubhouse as well.

Satellite Dishes/Antennas - By direction of the Federal Communications Commission, satellite dishes up to 1 meter in diameter and TV antennas up to 12 ft high may not be prohibited by neighborhood covenants or city ordinances. However, the SVHOA may still regulate placement of the dish. Please place dishes so that they are less visible to your neighbors. Satellite dishes greater than 1 meter in diameter must be screened from public view. Antennas greater than 12 ft high are not allowed. Approval not required.

Decks/Trellises/Gazebos/Pergolas - Must be constructed of a premium wood or a high-quality synthetic such as Trex. Wood construction should be painted or stained a natural wood color, or to match the house siding or trim. Approval required.

Patio Covers - If the cover has a solid roof, then it must be built as an extension of the home, extending from the existing structure, and using similar materials for siding, trim, windows and roof as were used in building your home. Paint colors should match those used on your home. If the cover has a lattice or slat type of roof, it may be built of any high-quality material. Examples of these types of patio covers may be found at the pools. A solid roof that emulates a lattice or slat style, by use of translucent material between the slats, or by a “lattice wrap” is also permitted. Approval required.

Enclosed Patios/Sunrooms - These must be built as an extension of the home, using similar materials for siding, trim, windows, and roof as were used in building your home. Paint colors should match those used on your home. Approval required.

Firepits – Fire pits are permitted in the backyard but shall meet the requirements of the Boise Fire Department for clear space from combustible materials and be properly permitted. Fire pits require a site inspection and permit by the fire department.

Solar Panels - Approval required.

Pet Enclosures - Dog runs and enclosures should be lower than the height of the nearest fence. If you have a split rail fence, you are encouraged to install an “invisible fence” system. If you wish to add a wire mesh to the split rail, it must be of high quality, with a large mesh size, installed on the house side of the fence, and may not extend higher than the fence posts. Approval required.

Mailboxes - Mailboxes and posts must match the original mailbox and post initially provided by the developer. Please ensure your mailbox and post are free from rust or damage. Paint is available for your use from the Farmhouse or if you prefer you may purchase your own paint (use Glidden Premium Exterior Satin Base 3 in Dark Hunter Green). If your mailbox is damaged, the SVHOA will replace your mailbox post and mailbox at no cost to you. Green vinyl 1” numbers are also available at the Farmhouse free of charge. Mailboxes are to be white, Postmaster General Rural Mailbox Standard Size.

House Numbers - Original house numbers or similar to those are encouraged to create harmony of graphic design throughout Surprise Valley. The Design Committee must specifically approve the use of alternate house numbers.

Nuisances - No rubbish or debris of any kind shall be placed or permitted to accumulate anywhere on the property. No odor or noise nuisances are permitted. No unsightly articles shall be permitted to remain on any lot as to be visible from any other portion of the property. You may not store items such as trash, recycling, compost and glass bins, lawn and gardening equipment, recreation equipment, other equipment, rubbish, etc. in a location where the items are visible from a street, sidewalk, or common area.

Fence Design and Maintenance

General:

- Fences within Surprise Valley must have design approval from the Design Committee. Because it is the intent of the Design Committee to tie the development together visually, only certain types of high-quality fences are allowed.
- Fences should be designed to be harmonious within a contiguous group of homes. An example of a contiguous group would be all the houses backing onto a Common Area. Backyard and side-yard fencing within this group should be harmonious as regards type, height, and setbacks.

Area Definitions:

- “Common Area” is defined as real property within Surprise Valley boundaries, which the SVHOA maintains for the mutual use and benefit of said local neighborhood association and its members.
- “Natural Area” is defined as an area generally left unmaintained and in its original state. Natural Areas include, but are not limited to:
 - South Bluff: Boise City, Idaho Power, and Eagle Christian Church, along the South Bluff;
 - Canyon Point: BLM and Ada County surrounding Canyon Point;
 - North Rim: SVHOA property along the North Rim.
- “Highway 21” is defined as the Highway 21 road right of way.

Allowed Fence Designs (Two Types):

- *Split Rail Fence:* A split rail fence approximately three feet high.
- *Solid Cedar Wood Fence:* A solid wood fence of the same type as is found bordering Surprise Way. The allowed height of this type of fence depends upon its location.

Fence Design Guidelines:

- No fences are allowed in front yards. (Particular attention to be paid when constructing fences on corner Lots.)
- For backyards of lots not bordering a Common Area and not on a rim-front, either a split rail or a solid wood fence is allowed. A solid wood fence may not exceed 6 feet high.
- For backyards of lots bordering a Common Area, fencing is discouraged. When permitted, only a split rail fence is allowed.
- For backyards of lots bordering Natural Areas on the North Rim and South Bluff, only a split rail fence is allowed.
- Any side-yard fence must be built as a “party wall.” (A common wall between two residences, which is also the legal dividing line between the two residences.) The application must be endorsed by both property owners.
- For side-yards of corner lots where the side-yard faces an interior street (other than Surprise Way), fencing is discouraged, but may be approved on a case-by-case basis.
- For side-yards of lots not bordering a Common Area, and not on a rim-front, either a split rail or a solid wood fence is allowed. A solid wood fence may not exceed 6 feet high.
- For side-yards of lots bordering a Common Area or on a rim-front, either a split rail or a solid wood fence is allowed. The height of a solid wood fence must not exceed 6 feet at any point. As the fence approaches the rear lot line, the fence height must step down to no higher than 4 feet. The lower height must continue, at the minimum, for 20 feet from the rear lot line. Setbacks greater than 20 feet may be required to achieve a consistent look with your neighbors, or to maintain a neighbor’s view of the Common Area or rim.
- Canyon Point - Special Rule for Side Yard Fences (*Adopted by the SVHOA Design Committee, October 3, 2006. This rule applies only to those lots whose rear yards face the bluff. It does not apply to lots along Highway 21.*) Side yard fences may be either split rail or solid wood. Split rail fences must be 4 ft in height along their entire length. Solid wood fences may be either 4 ft or 6 ft in height. If a solid wood fence is 6 ft in height, it must be stepped down to 4 ft prior to the connection with the rear fence. To determine the point of transition from 6 ft to 4 ft use the rear corner of the applicant's home and the adjacent rear corner of the neighboring home (on the side

where the fence is to be built). Draw a line from the rear corner of the neighbor's home to the rear corner of the applicant's home. Find the point at which the side property line intersects this drawn line. From this point of intersection and continuing to the rear property line the fence may not exceed 4' in height. From the front plane of the house back to the drawn line the fence may be 6 ft in height. The last panel of the 6 ft section must angle down over its length from 6 ft to 4 ft.

- Fencing installed on the interior of a lot, such as for a privacy screen around a deck, is not permitted. Instead, build an architectural extension of your home, using similar materials for siding and trim, and matching colors. Exceptions are permitted for the purpose of screening utility meter panels and heating/air conditioning units.
- Pet Enclosures: Dog runs and enclosures should be lower than the height of the nearest fence. Homeowners with split rail fences are encouraged to install an "invisible fence" system. With approval, wire mesh may be added to the split rail, but it must be of high quality, with a large mesh size, installed on the house side of the fence, and may not extend higher than the fence posts.

Fence Maintenance:

- Split rail fences along Surprise Way, from Amity Road to the west Surprise Valley Subdivision entrance are maintained by the SVHOA.
- Solid wood fences along Surprise Way reflect the overall appearance of the neighborhood and are maintained for the benefit of the community. The SVHOA will maintain all developer installed solid wood fences bordering Surprise Way. In addition to normal repairs, SVHOA will periodically pressure wash and stain the Surprise Way side of these solid wood fence. The homeowner's responsibility for maintenance of these solid wood fences is as follows:
 - The homeowner shall prevent soil buildup against the fence and sprinkler overspray that can cause the fence to decay. Damage to the fence can also occur from the tree and shrub roots and/or branches pushing against the fence. In a further effort to maintain the fence appearance homeowners are responsible for clearing trees, and shrubs that extend into and over the fence.
 - Although the SVHOA will maintain the fence under normal conditions, any fence repairs/replacement due to damage caused by the homeowner, the homeowner's pets, their contractors, or by the homeowner failing to properly maintain their side of the community fence, shall be the responsibility of the homeowner.
 - Pickets are attached from the homeowner's side of the fence; therefore, homeowner are expected to reattach loose pickets as needed.
- All homeowner installed split rail and solid wood fences (including fences bordering boarding Common Areas, Natural Areas and Highway 21) shall be maintained in good appearance/condition at the expense of the homeowner of the lot on which they are located. This includes replacing damaged and rotted pickets, posts, rails and gates; as well as maintaining stain applied to fences.
- Homeowners' shall make repairs to damaged fences promptly. The Neighborhood Manager can supply names of fencing contractors, if needed.
- Homeowners who believe their split rail fence boarding a Common Area was damaged by the SVHOA landscape contractor should contact the Neighborhood Manager. If the Neighborhood Manager determines the split rail fence was damaged by the landscape contractor then a reasonable number of replacement split rail posts will be provided at no charge to the homeowner to install.

Fence Stains:

- Homeowner's are encouraged to treat their fences with a clear sealer or a stain to maintain the fence appearance and longevity of their fences.
- Any clear sealer or transparent (unpigmented) stain is permitted without prior approval. If the homeowner wishes to apply a pigmented stain to their solid wood fence, the SVHOA encourages you to use **Behr Brand with color Woodbridge SC-116** (to be consistent with the cedar fencing bordering Surprise Way) available at Home Depot. Approval is required for all other stain colors. House paint is not allowed.
- Semi-transparent stains show the wood grain, so you must thoroughly pressure wash the fence before application to remove any underlying stains. The semi-transparent stain typically should be re-applied every 3 years and solid stains should be reapplied every five years.

Gates:

- High quality gates are allowed for backyard split rail fences bordering Common Areas. Wrought iron gates three feet in height are preferred and will be the responsibility of the respective homeowner to install and maintain.
- No gates were included in original solid wood fencing by the developer for fences bordering Surprise Way and the installation of such backyard gates is not allowed. Where "homeowner installed gates" exist, the respective homeowner is responsible for any maintenance and replacement of these gates and support posts.

Right to Repair:

- If after being given reasonable notice by the SVHOA, the fence and gate repairs are not made by the homeowner, the SVHOA may contract the work and all associated costs will be assigned to the respective owner of the property.

Community Contacts

All Emergencies	911
ACHD	208-387-6100
Ada County Assessor	208-287-7200
Animal Control	208-343-3166
Boise City Planning & Development	208-384-3830
Boise City Utilities	208-384-3735
Boise Police Non-Emergency	208-377-6790
Dig Line, Inc.	811
Idaho Power (Outages) Outage Map	208-388-2323
Intermountain Gas	208-377-6840
Republic Services	208-345-1265
Storm Water Pollution Hotline	208-395-8888
Viola Water	208-362-7304
Idaho Firewise, Inc.	www.idahofirewise.org
Nextdoor	www.nextdoor.com